



Tongue & Groove cuttersets

- radially relieved, solid HL steel

Specification

Solid HL steel T&G, TG&V and TG & Double V cuttersets, 59.96mm or 60.00mm bore, Z=4,6 or 8, 180mm Diameter. Screw adjustable, with 3 drive pins. Nmax 8000 revs/min. Mechanical feed (MEC) only.

Application

For mounting on mechanical or hydraulic sleeves.

For machining solid timber.

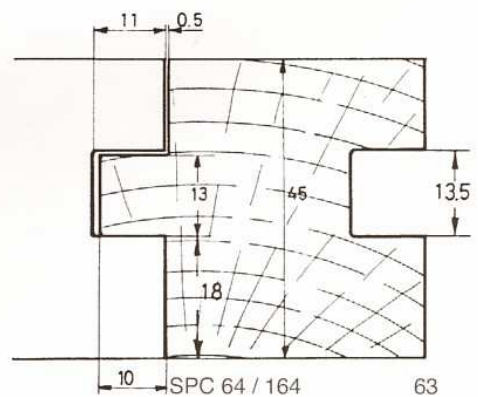
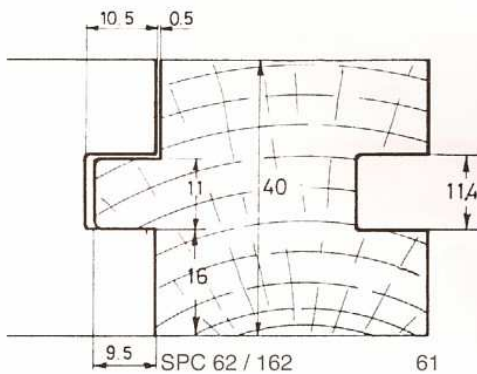
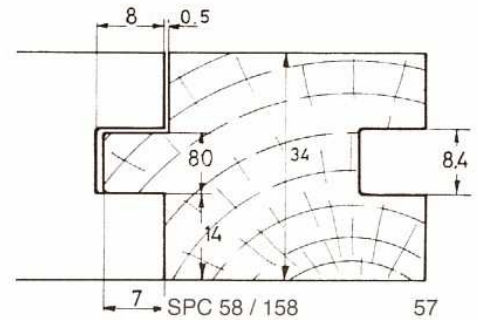
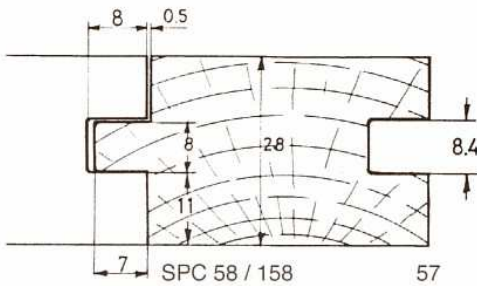
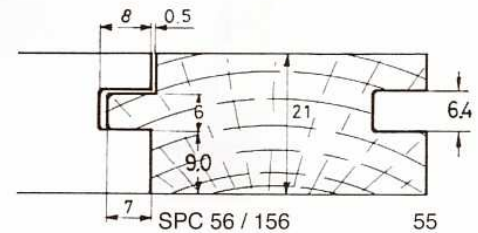
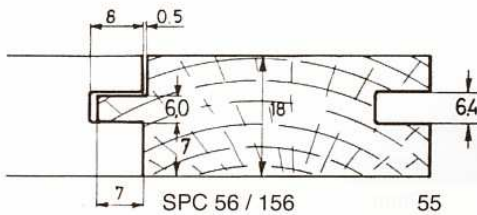
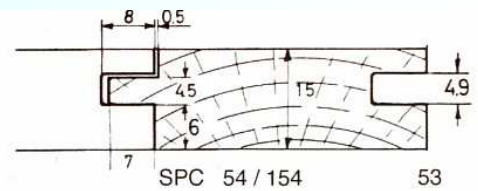
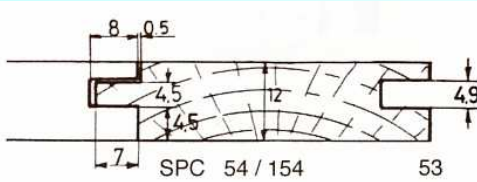

See over for standard TGV, TGDV sizes

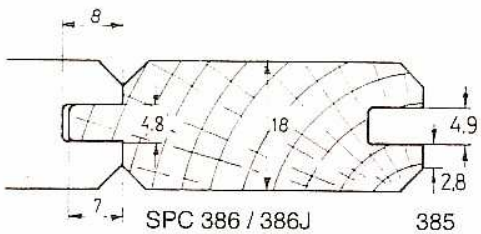
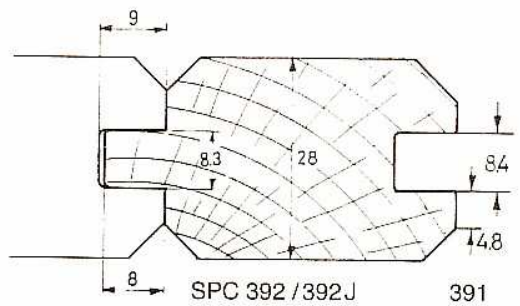
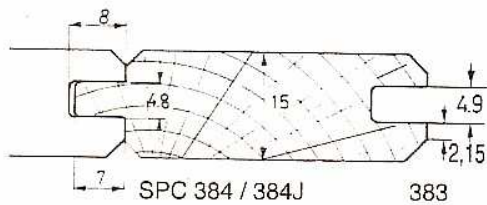
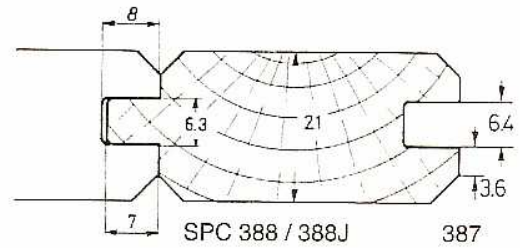
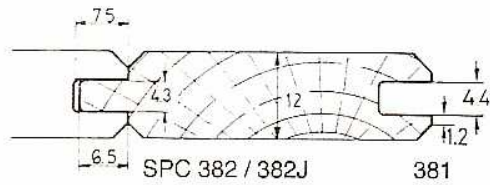
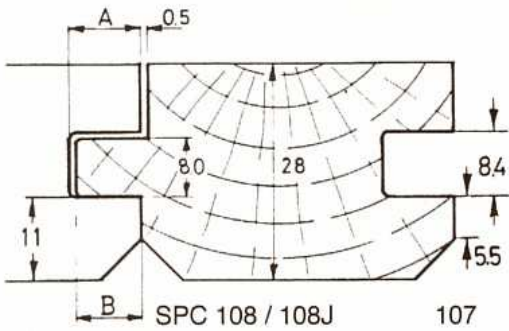
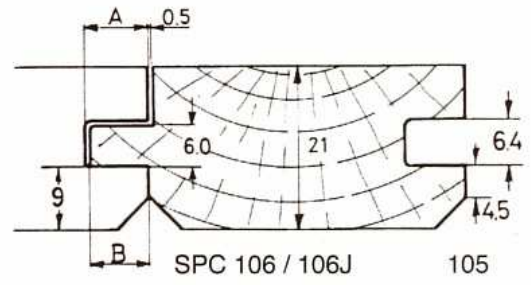
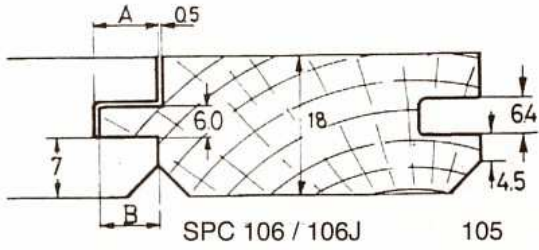
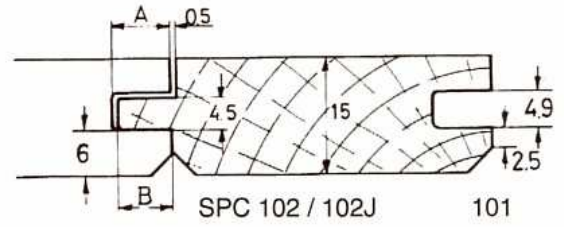
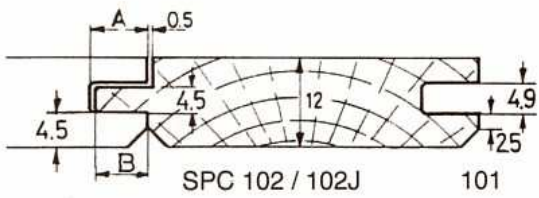

Special profiles made to order.

Standard range of deep groove T&G also available.



COLTON TOOLING LTD

4 HIGHMERES ROAD, THURMASTON
LEICESTER LE4 9LZ

TEL: +44 (0)116 276 6225

FAX: +44 (0)116 276 6226