



Hydraulic precision chuck

Type "G" for overhead routers.

Specification

Hydraulically self-centering high precision router chuck. A self contained sealed hydraulic system within the chuck simultaneously centralises and clamps the cutting tool with the turn of one actuation screw.

A unique two-part safety system comprising double seals for the hydraulic system and a further mechanical safety guard ensures tool retention in any circumstances.

Application

For use on overhead routers, choice of ten different mounting shanks including the new HSK63F.

Shanks available, MK2, MK3, ISO40, SK30, SK40, BT30, BT35, BT40, HSK 63F and SCM (30)

Operation

Tightening the pressure screw acts on the piston to force the pressure medium in the hydraulic system into the narrow space around the clamping part, which then centres and clamps the tool.

Full clamping pressure is obtained when the pressure screw is tightened to the end of its travel. Releasing the pressure screw reduces the pressure and the clamping part returns to its original dimensions. The tool can now be removed.

Clamping Mechanism

The mechanism for clamping is designed to give maximum security. It consists of a pressure screw and piston. The piston has two independent sealing systems, hydraulic sealing in the form of an o-ring and mechanical sealing using a steel ball into a spherical seating. When the pressure screw is tightened to its end position then both systems are brought into operation, the tool is clamped, and the cover ring is twisted to cover the screw and protect from dust etc.

Mechanical safety guard

The safety guard consists of a spring activated disc. When the guard is pressed in, the mechanism is opened and the screw head of the tool can pass. When the guard is released the tool is prevented from falling out by the disc retaining the head of the adjustment screw.

Note! For the safety guard to function, the tool must be fitted with an adjustment screw.

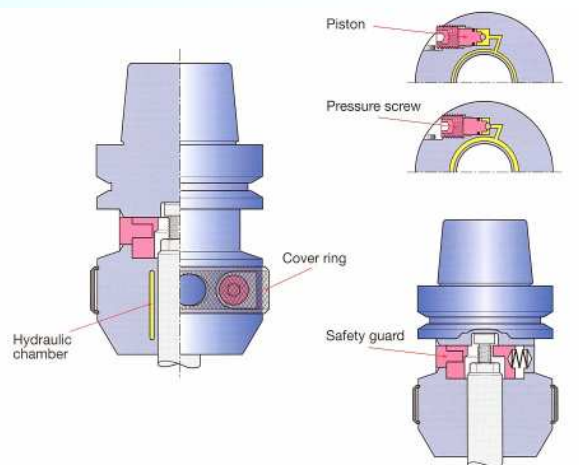

Mounting dimensions of the tool.

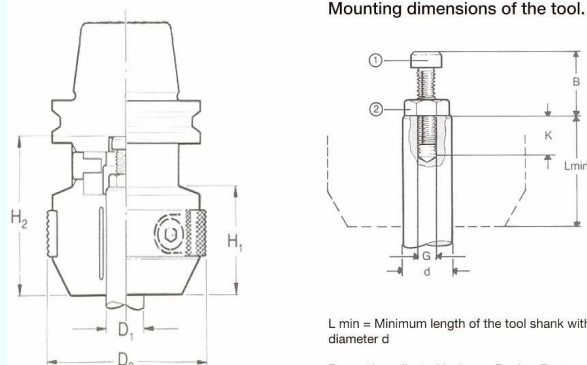

L min = Minimum length of the tool shank with diameter d

B must be adjusted between B min - B max

K = Minimum thread depth in shank

Chuck		Tool shank										①	②	
Type	D ₁ mm	D ₂ mm	H ₁ mm	H ₂ mm	d	L min mm	B min mm	B max mm	K mm	G mm	ISO 4762	ISO 4035		
G-12	12	55	26	45.5	12	29	17	22	16	M6	M6x25	M6		
G-16	16	58	32	51.5	16	35	17	22	16	M6	M6x25	M6		
G-20	20	63	38	59.5	20	41	19	24	16	M8	M8x25	M8		
G-25	25	67	45.5	67	25	48.5	19	24	16	M8	M8x25	M8		
G-1/2"	12.700	55	27.5	47	1/2"	30.5	17	22	16	M6	M6x25	M6		
G-5/8"	15.875	58	32	51.5	5/8"	35	17	22	16	M6	M6x25	M6		
G-3/4"	19.050	63	36.5	58	3/4"	39.5	19	24	16	M8	M8x25	M8		
G-1"	25.400	67	45.5	67	1"	48.5	19	24	16	M8	M8x25	M8		
Speed max 25000 rpm					Tolerance on the tool shank:									
					$\begin{matrix} \text{h7} \left\{ \begin{matrix} 0 \\ -0.018 \end{matrix} \right. \\ \text{g6} \left\{ \begin{matrix} -0.006 \\ -0.017 \end{matrix} \right. \end{matrix}$				$\begin{matrix} \text{h7} \left\{ \begin{matrix} 0 \\ -0.021 \end{matrix} \right. \\ \text{g6} \left\{ \begin{matrix} -0.007 \\ -0.020 \end{matrix} \right. \end{matrix}$					



COLTON TOOLING LTD

4 HIGHMERES ROAD, THURMASTON
LEICESTER LE4 9LZ

TEL: +44 (0)116 276 6225

FAX: +44 (0)116 276 6226