



# Hydraulic Planing Cutterheads (Steel Body)

## Specification

Hydraulically self centring tools. These tools are manufactured from high tensile steel, fitted with hardened wedges for durability, and are designed to accept 3 mm thick planer blades as standard.

## Application

For use on mechanically fed planing and moulding machines, for higher production rates.

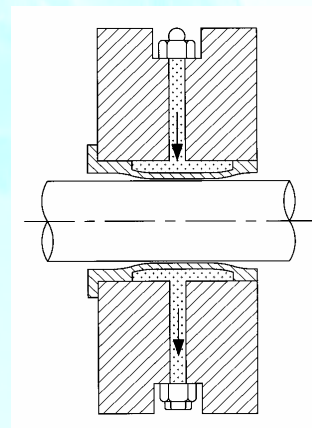

Part Number	Cutting Circle Dia	Working Width	Body Width (mm)	Total Width (mm)	Bore Width (mm)	Knives Diameter (mm)	Hook (mm)	Angle (deg)
								D
HBP406040137HA27	143	60	60	74	40	4	27	
HBP410040137HA27	143	100	100	114	40	4	27	
HBP413040137HA27	143	130	123	137	40	4	27	
HBP415040137HA27	143	150	150	164	40	4	27	
HBP418040137HA27	143	180	180	194	40	4	27	
HBP423040137HA27	143	230	223	237	40	4	27	
HBP406050155HA27	163	60	60	74	50	4	27	
HBP410050155HA27	163	100	100	114	50	4	27	
HBP413050155HA27	163	130	123	137	50	4	27	
HBP415050155HA27	163	150	150	164	50	4	27	
HBP418050155HA27	163	180	180	194	50	4	27	
HBP423050155HA27	163	230	223	237	50	4	27	
HBP426050155HA27	163	260	253	267	50	4	27	
HBP431050155HA27	163	310	303	317	50	4	27	
HBP606050155HA27	163	60	60	74	50	6	27	
HBP610050155HA27	163	100	100	114	50	6	27	
HBP613050155HA27	163	130	123	137	50	6	27	
HBP615050155HA27	163	150	150	164	50	6	27	
HBP618050155HA27	163	180	180	194	50	6	27	
HBP623050155HA27	163	230	223	237	50	6	27	
HBP626050155HA27	163	260	253	267	50	6	27	
HBP631050155HA27	163	310	303	317	50	6	27	
HBP806050155HA25	163	60	60	74	50	8	25	
HBP810050155HA25	163	100	100	114	50	8	25	
HBP813050155HA25	163	130	123	137	50	8	25	
HBP815050155HA25	163	150	150	164	50	8	25	
HBP818050155HA25	163	180	180	194	50	8	25	
HBP823050155HA25	163	230	223	237	50	8	25	
HBP826050155HA25	163	260	253	267	50	8	25	
HBP831050155HA25	163	310	303	317	50	8	25	

The above is a list of our more popular range of products designed around the Weinig standard size range. We would be pleased to receive your enquiries for any specific requirements you may have for items not listed. Tools can be made with or without hubs. Please specify dimensions detailed on the sketch overleaf when enquiring or ordering.

Part Number	Cutting Circle (mm)	Working Width (mm)	Body Width (mm)	Total Width (mm)	Bore Dia (mm)	Knives	Hook Angle (deg)
	D	B	B1	B2	d	Z	
HBP610040195HA27	203	100	100	114	50	6	27
HBP615040195HA27	203	150	150	164	50	6	27
HBP623040195HA27	203	230	223	237	50	6	27
HBP626040195HA27	203	260	253	267	50	6	27
HBP631040195HA27	203	310	303	317	50	6	27
HBP633040195HA27	203	330	323	337	50	6	27
HBP810050195HA27	203	100	100	114	50	8	27
HBP815050195HA27	203	150	150	164	50	8	27
HBP823050195HA27	203	230	223	237	50	8	27
HBP826050195HA27	203	260	253	267	50	8	27
HBP831050195HA27	203	310	303	317	50	8	27
HBP833050195HA27	203	330	323	337	50	8	27
HBP1010050195HA23	203	100	100	114	50	10	23
HBP1015050195HA23	203	150	150	164	50	10	23
HBP1023050195HA23	203	230	223	237	50	10	23
HBP1026050195HA23	203	260	253	267	50	10	23
HBP1031050195HA23	203	310	303	317	50	10	23
HBP1033050195HA23	203	330	323	337	50	10	23
HBP1210050195HA23	203	100	100	114	50	12	23
HBP1215050195HA23	203	150	150	164	50	12	23
HBP1223050195HA23	203	230	223	237	50	12	23
HBP1226050195HA23	203	260	253	267	50	12	23
HBP1231050195HA23	203	310	303	317	50	12	23
HBP1233050195HA23	203	330	323	337	50	12	23
HBP1410050195HA23	203	100	100	114	50	14	23
HBP1415050195HA23	203	150	150	164	50	14	23
HBP1423050195HA23	203	230	223	237	50	14	23
HBP1426050195HA23	203	260	253	267	50	14	23
HBP1431050195HA23	203	310	303	317	50	14	23
HBP1433050195HA23	203	330	323	337	50	14	23
HBP1610050195HA20	203	100	100	114	50	16	20
HBP1615050195HA20	203	150	150	164	50	16	20
HBP1623050195HA20	203	230	223	237	50	16	20
HBP1626050195HA20	203	260	253	267	50	16	20
HBP1631050195HA20	203	310	303	317	50	16	20
HBP1633050195HA20	203	330	323	337	50	16	20

The above is a list of our more popular range of products designed around the Weing standard size range. We would be pleased to receive your enquiries for any specific requirements you may have for items not listed. Tools can be made with or without hubs.

Please specify dimensions detailed on the sketch when enquiring or ordering.

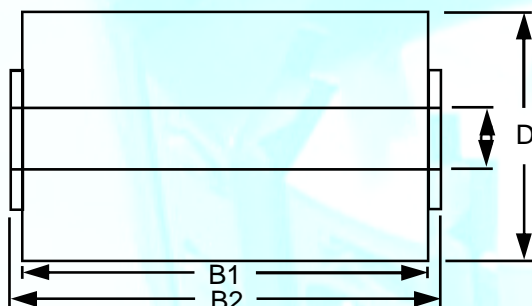

**4 HIGHMERES ROAD, THURMASTON  
LEICESTER LE4 9LZ  
TEL: +44 (0)116 276 6225  
FAX: +44 (0)116 276 6226  
coltontooling@ukonline.co.uk**